



CORUÑA
PRÓXIMA



//ABANCA



SNiPE Class International Racing Association
Commodore Hub E. Isaacks Trophy
O'Leary Trophy
Earl Elms Perpetual Trophy
Snipe World Championship
5th to 11th August 2017
Real Club Náutico de La Coruña



SAILING INSTRUCTIONS



- [DP] Denotes a rule for which the penalty is at the discretion of the International Jury and may be less than disqualification.
[NP] Denotes that a breach of this rule will not be grounds for protest by a boat.
[SP] Denotes a rule which a penalty may be applied by the Race Committee without a hearing (this changes RRS 63.1).

1 RULES

- 1.1 The race will be governed by:
- 1.1.1 The rules as defined in the World Sailing (WS) Racing Rules of Sailing ("RRS");
 - 1.1.2 Appendix P will apply;
 - 1.1.3 The SCIRA Rules of Conduct for International Events (RoC), except any reference to the National Prescriptions;
 - 1.1.4 The Deeds of Gift for the **World Championship**;
 - 1.1.5 If there is a conflict between the Notice of Race and the Sailing Instructions, the Sailing Instructions will prevail (*Changes Rule 63.7 RRS*);
 - 1.1.6 Use of personal flotation device (minimum standard EN 393 or ISO 12402-5 Level 50) is mandatory at any moment while afloat (*Changes Preamble of Part 4 RRS*). [NP];
 - 1.1.7 Any national prescriptions that applies will be published on the ONB;
 - 1.1.8 The decision of the International Jury will be final (RRS 70.5);
 - 1.1.9 Appendix T will apply.
 - 1.1.10 The official language is English.

2 IDENTIFICATION [NP] [DP] – Attachment 3

- 2.1 Boats shall display bow numbers. The OA will supply the numbers.
- 2.2 Boats will display a ribbon of the colour of his group attached to the mainsail head halyard grommet

3 NOTICES TO COMPETITORS

- 3.1 Notices to competitors will be posted on the Official Notice Board (ONB) located at the window close to the race office.

4 CHANGES TO SAILING INSTRUCTIONS

- 4.1 Any change to the sailing instructions will be posted on the ONB before Flag "D" is displayed ashore on the day it will take effect, except that any change to the schedule of races will be posted by 2000h. on the day before it will take effect.

5 SPECIAL SIGNALS

Ashore

- 5.1 Signals made ashore shall be displayed from the Main Flag Pole (MFP) located at close to the ramp. When a signal is displayed over a fleet flag, it applies to that fleet only. (*Change Race Signals Preamble RRS*)
- 5.2 Flag "D" with one sound means: **"The warning signal will be made not less than 50 minutes after Flag D is displayed. Boats are requested not to leave the boat parking until this signal is made, except with the authorization from the Race Committee"**. [NP] [DP]

Racing Area

- 5.3 When **AP or N over H or A** are displayed in a Race Committee Vessel together with the Pennant 8 means: **"Competitors must go to the harbour immediately"**. The infringement of this rule will be penalized by Race Committee adding **5 points**, without a hearing, to the offender boats as established by rule 64.1 d) RRS. (*Changes rules 63.1 and A5 RRS*). [SP]

6 SCHEDULE

- 6.1 On the first sailing day a skippers meeting will be held at 11:00h close to the boats parking.
- 6.2 The warning signal for the first race on 7th, 8th, 9th, 10th and 11th will be made at 13.00.
- 6.3 Eleven races (11) are scheduled and three (3) races are required to constitute a series.
- 6.4 The Race Committee reserves the right to decide the number of races to be sailed per day, except that no more than three (3) races shall be sailed per day.
- 6.5 No warning signal will be made last day after 16:00h, except as a consequence of a General Recall.

7 CLASS FLAG

- 7.1 The Class Flag will be:
 - Snipe silhouette on a yellow background
 - Snipe silhouette on a blue background

8 RACING AREA. OFFICIAL VESSEL IDENTIFICATION

- 8.1 Attachment 1 shows the Racing Area location.



- 8.2 Race areas will be identified as follows:
 Alfa Area: ICF "A" Flag
 Bravo Area: ICF "B" Flag
 The Race Committee will display at the MFP the racing area flag with the "D" flag to indicate the racing area for the day
- 8.3 **Race Committee Vessels** will display a **colour area flag**. The **Jury Vessels** will display a **black "J" on a white background**.
Measurers vessel will display a **black "M" on a white background**

9 COURSES

- 9.1 Attachment 2 shows the courses, including course signals, angles between legs, the order in which marks are to be passed and the side on which each mark is to be left.
- 9.2 The Race Committee will lay a course to be sailed in 60-75 minutes for the first boat. Failing to meet this time will not be grounds for redress. *(Changes rule 62.1 a) RRS)*
- 9.3 The RC Signal Vessel may display the approximate compass bearing to Mark 1 before the Warning Signal, and the course signal flag "O", "W" or "T" shall be displayed no later the Warning Signal.

10 MARKS

- 10.1 Course marks will be inflatable troncoconical **RED**
- 10.2 Change of Course Marks shall be inflatable troncoconical **YELLOW**
- 10.3 **Starting marks** Race Committee Vessel and Pin end Vessel.
- 10.4 **Finishing marks** Race Committee finish Vessel on the starboard end and a red cylindrical mark on the port end.
- 10.5 A Race Committee Vessel signalling a change of course, according to SI 12.2, is considered as a mark.

11 THE START

- 11.1 The **starting line** will be between a staff on the Race Committee Vessel at the starboard end and a staff Pin end Vessel, both of them displaying an **ORANGE flag**.
- 11.2 A boat starting later than **4 minutes** after her starting signal will be scored Did Not Start ("DNS"). *(This changes RRS A4 and A5).*
- 11.3 Boats called OCS, ZFP or UFD may be displayed in the Race Committee finish Vessel of that race. The failure to post or an incomplete or wrong posting will not be grounds for redress. *(Changes rule 62.1 a) RRS)*
- 11.4 To alert boats that a race will begin soon, an **ORANGE** flag will be displayed with one sound signal at least **5 minutes** before a warning signal is displayed. This flag shall be removed 4 minutes after a valid start with no sound signal.

12 CHANGE OF COURSE AFTER THE START

- 12.1 To change the next leg of the course, the race committee will lay a new mark (or the finishing line) and remove the original mark as soon as practicable. When in a subsequent change a new mark is replaced, it will be replaced by an original mark.
- 12.2 Except at a gate, boats shall pass between the race committee vessel signalling the change of the next leg and the nearby mark, leaving the mark on port and the race committee Vessel on starboard. *(Changes rule 28 RRS)*
- 12.3 If a change of course is done to windward, the offset mark (mark 2 in "W" course) will not be set and boats will sail from mark 1 to gate 3. If the change of course is done to leeward, the gate 3 will be a single mark to leave on port.

13 THE FINISH

- 13.1 The **finishing line** will be between the staff at Race Committee Vessel carrying an **ORANGE flag** and a red cylindrical mark.
- 13.2 **Pennant Two** displayed at the Race Committee Finish Vessel means: "The Race Committee will start another race as soon as practical".

14 PENALTIES

- 14.1 Any boat taking a Penalty shall fill a form at the Race Office before the time limit to protest. *(Addition to RRS 44) [NP]*

15 LEADERS IDENTIFICATION

- 15.1 Each day, the first, second and third boats in series ranking at the beginning of the day are required to collect and wear while sailing a colored Bib (Yellow, blue and red). The OA will supply those Bib's and instructions for their use.

16 TIME LIMIT

- 16.1 Time limit for the first boat to complete the first lap is 40 minutes. If no boat has completed the first lap within the time limit the race shall be abandoned. For the purpose of this rule a lap means the rounding of Mark 3 for the first time. *(This change RRS 32.1)*
- 16.2 The time limit for the first boat to finish a race is 90 minutes. Boats failing to finish within 30 minutes after the first boat sails the course and finishes will be scored Did Not Finish ("DNF") *(This changes RRS 35, A4 and A5).*

17 PROTEST AND REQUEST FOR REDRESS

- 17.1 Protests Forms are available at the Race Office. Protests and request for redress or reopening shall be delivered within the appropriate time limit.



17.2 Time to protest:

- a) The Protest Time Limit shall be **sixty (60) minutes** for each fleet after the last boat has finished the last race of the day or the Race Committee signals no more racing today, whichever is later. The resulting time will be posted at the ONB.
- b) A **request for reopening** shall be delivered:
 - i) Within the protest time limit if the requesting party was informed of the decision on the previous day;
 - ii) **No later than fifteen (15) minutes** after the party requesting the reopening was informed of the decision on the last day and after finishing the qualifying series. (*Changes rule 66 RRS*)

17.3 The International Jury will publish on the ONB boats that has been penalized under rule 42 RRS according to the Appendix P.

17.4 Notices will be posted on the ONB **not later than 30 minutes** after the protest time limit to inform competitors of hearings in which they are parties or named as witnesses. Hearings will be held in the protest room, beginning at the posted time.

17.5 Within the protest time limit, the Race Committee shall post on the ONB the boats that are disqualified or penalized under A5. A boat so notified may only request for redress within 30 minutes after that posting. (*Changes rule 62.2 RRS*)

17.6 Notices of protests by the Race Committee or the International Jury will be posted on the ONB to inform boats under rule 61.1 b).

18 **FORMAT AND SCORING**

18.1 **FORMAT OF RACING**

Boats will sail in groups.

The regatta will consist of a Qualifying Series and a Final Series.

18.2 **QUALIFYING SERIES**

18.2.1 For the Qualifying Series boats will be assigned to Yellow and Blue Fleets of, as nearly as possible, equal size and ability.

18.2.2 Initial fleet assignments will be made by a Committee appointed by the Organizing Authority, and posted by 20.00 on August 6th.

18.2.3 During the Qualifying Series boats will be reassigned to fleets after each day of racing, except if on the first day only one race is completed. If all fleets have completed the same number of races, boats will be reassigned based on their results of the overall at that moment. If all fleets have not completed the same number of races, the reassignment will be based on their results of the overall completed by all the fleets.

Reassignments will be made as follows:

Overall	Fleet assignment
First	Yellow
Second	Blue
Third	Blue
Fourth	Yellow
Fifth	Yellow
Sixth	Blue
Seventh	Blue
Eighth	Yellow
Ninth	Yellow

and so on

18.2.4 Assignments will be based on the overall available at 21:00h that day regardless of protests or requests for redress not yet decided.

18.2.5 If both fleets have not completed the same number of races by the end of a day, the fleet with fewer races will continue racing the following day until both fleets have completed the same number of races. All boats will thereafter race in the new fleets.

18.2.6 A maximum of six (6) races are scheduled for the Qualifying Series.

18.3 **FINAL SERIES**

18.3.1 Boats will be assigned to Final Series Fleets Gold and Silver on the basis of their ranks in the Qualifying Series. The half of the fleet of the overall in the Qualifying Series will be assigned to the Gold fleet. The other half of the fleet in the qualifying series will be assigned to the Silver fleet.

18.3.2 Any recalculation of Qualifying Series rankings after boats have been assigned to final series fleets will not affect the assignments except that a redress decision may promote a boat to a higher fleet.

18.3.3 A maximum of seven (7) races are scheduled for the Final Series depending in the results of the qualifying series.

18.4 **SCORING**

18.4.1 THREE (3) Qualifying races are required to be completed by all fleets to constitute a regatta.

18.4.2 FOUR (4) races are required to be completed by each fleet to constitute a Qualifying Series. If FOUR (4) races are not completed, the Qualifying Series will be extended to complete them.

18.4.3 The position of the qualifying races will pass to the final series as the first race of this final series and this race will not be excluded of the final series.

18.4.4 If at the end of the qualifying series some boats have more race completed than others, scores for the most recent races will be excluded so that all boats have the same number of race completed.

18.4.5 Rule A4.2 is changed so that the scores are based on the number of boats assigned to the largest fleet.

18.4.6 Each Final Series fleet will be scored separately. Different final series fleets don't need to complete the same number of final races. The boats in the Gold fleet will be ranked always over silver fleet.

18.4.7 Series Scores:

- i) **Qualifying series:** When fewer than 4 races have been completed in the qualifying series, a boat's series score will be the total of her races scores. With 4 or more races completed, the worst result will be excluded from the series.



- ii) **Final series:** When fewer than 3 races have been completed in the final series (not including the first race described in S118.4.3), a boat's series score will be the total of her races scores. With 3 or more races completed, the worst result will be excluded from the series except the overall results of the qualifying series.

19 SECURITY RULES & SAFETY VESSELS

- 19.1 Boats retired (RET) or those boats that leave the Race Area before finishing (DNF) shall fill a form within the protest time limit. **[NP][DP]**
- 19.2 When flag "F" is displayed ashore, all competitors shall sign the **Check In Form** at the Race Office within the protest time limit to confirm that all competitors are ashore.
Flag "F" will be displayed, at least, 30 minutes before the protest time limit. **[NP] [DP]**
- 19.3 Under all circumstances, coaches and other support vessels are expected to assist any boat in danger.

20 CHANGE OF CREW **[NP]**

- 20.1 Only the crew can be changed (not the skipper).
- 20.2 Requests for a change of crew shall be submitted **in writing** to the Race Committee, that may give permission **only** in case of illness (the Race Committee may request a medical certificate), accident or any other circumstances.
- 20.3 Requests for a change shall be lodged in the Race Office before 1100h of the day of the race. In emergency case, the **Race Committee** may grant the change after this time.

21 EQUIPMENT AND MEASUREMENT CHECKS **[DP] [NP]**

- 21.1 A boat or equipment may be inspected at any time for compliance with the Class Rules and Sl's.
- 21.2 On the water, a boat shall act in accordance with any instruction by the measurer to proceed immediately to a designated area for inspection.

22 DISPOSAL OF REFUSE

- 22.1 In addition to rule 55 RRS, trash may be placed aboard support and Committee Vessels. The penalty for breaching rule 55 RRS will be decided by the International Jury and could be different than a disqualification.

23 SUPPORT VESSELS **[NP]**

- 23.1 Team leaders, coaches and other support personnel shall be outside of the racing area described in SI 23.2 and 23.3 from the Preparatory Signal until the last boat finishes the race or if the Race Committee displays a postponement, general recall or abandonment, unless they are helping a boat in danger. Breaking this rule will be penalized by the International Jury. **[DP]**
- 23.2 The **racing area** is defined as a surface which borders are over 50 meters of the minimum track of a boat racing.
- 23.3 The **starting area** is a rectangle with its borders 50 meters to windward, leeward and 100 meters to pin ends of the starting line.

24 RADIO COMMUNICATION **[DP] [NP]**

- 24.1 A boat shall neither make or receive radio transmissions while racing nor receive radio communications not available to all boats, except in an emergency or when using equipment provided by the race committee. This restriction also applies to mobile telephones.

25 DISCLAIMER OF LIABILITY

- 25.1 Competitors participate in the event entirely at their own risk. See RRS 4, Decision to Race. The Organizing Authority will not accept any liability for material damage or personal injury or death sustained in conjunction with or prior to, during, or after the regatta.
- 25.2 Sailing is by its nature an unpredictable sport and therefore inherently involves an element of risk. By taking part in the event, each competitor and the responsible adult agree and acknowledges that:
- They are aware of the inherent element of risk involved in the sport and accept responsibility for the exposure of themselves and their boat to such inherent risk whilst taking part in the event;
 - They are responsible for the safety of themselves, their boat and their other property whether afloat or ashore;
 - They accept responsibility for any injury, damage or loss to the extent caused by their own actions or omission;
 - Their boat is in good order, equipped to sail in the event and they are fit to participate;
 - The provision of a race management team, patrol boats and other officials and volunteers by the event organizer does not relieve them of their own responsibilities;
 - The provision of patrol boat cover is limited to such assistance, particularly in extreme weather conditions, as can be practically provided in the circumstances.

26 RIGHTS TO USE NAME AND LIKENESS

- 26.1 By participating in this event, competitors automatically grant to the OA and the event sponsors the right, in perpetuity, to make, use, and show, at their discretion, any photography, audio and video recording, and other reproductions of them made at the venue or on the water from the time of their arrival at the venue, until their final departure, without compensation.



Attachment 1

RACE AREA

AREA "A": INSAIDE SAILING AREA



AREA "B": OUTSIDE SAILING AREA



HOW TO SAIL OUT TO THE SAILING AREA OF PARTICIPANTS FROM “EL PARROTE”:



Attachment 2

Code flag "W"

start - 1 - 1bis - gate(3s/3p) - 1 - 1bis
- gate(3s/3p) - finish

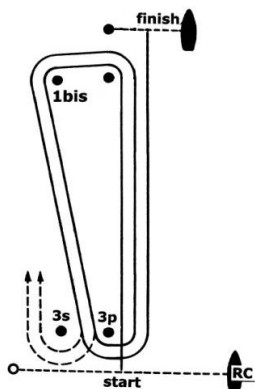

Code flag "0"

start - 1 - 2 - 3 - 1 - 3 - finish

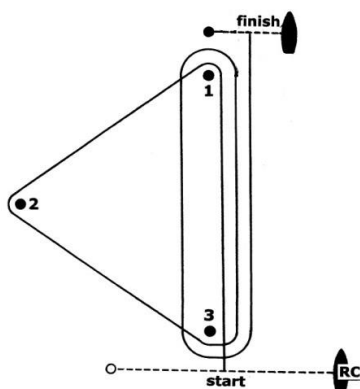

Code flag "T"

start - 1 - 2 - 3 - 1 - 2 - 3 - finish

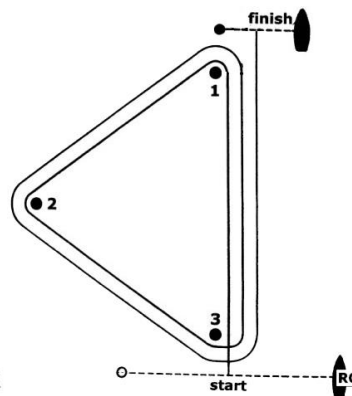

Attachment 3

BOW NUMBER

Bow number will be fixed by following the diagram.

